

# Determination of the Muon Lifetime

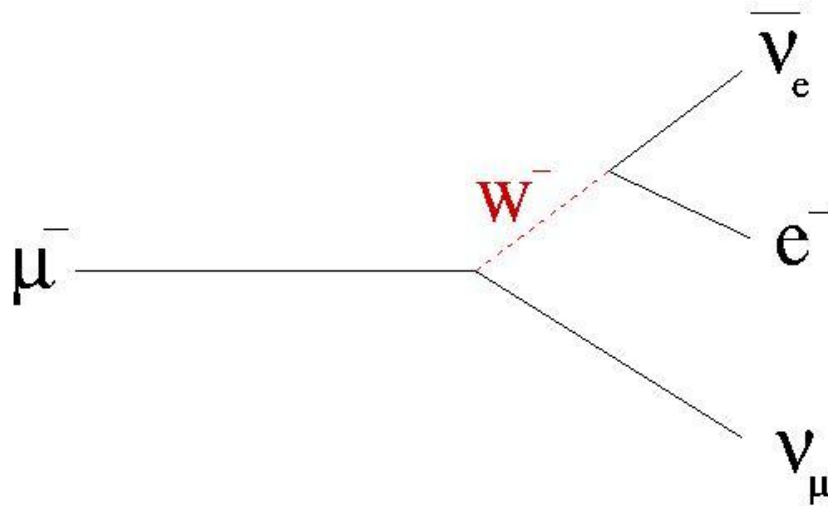

## 1. Introduction

Welcome to the muon ( $\mu$ ) decay experiment. The purpose of this experiment is to measure the lifetime of one of the elementary particles of matter, the muon. There are six so-called leptons: the electron ( $e$ ), the muon, the tau ( $\tau$ ) lepton plus their associated neutrinos ( $\nu_e, \nu_\mu, \nu_\tau$ ) [3,4]. The muon and the tau leptons have identical properties to those of the electron except that they are heavier. One of the great mysteries of particle physics is the origin of this mass difference.

In this experiment you will measure the muon lifetime. The first experiment to measure the muon lifetime was by Rossi [5], but the setup we use is similar to the one proposed by Hall, Lind and Ristinen [6]. A muon that enters, stops, and subsequently decays in a scintillator gives rise to two pulses separated by a few microseconds, one when it enters the liquid, and a second one when it decays. The pulses can be viewed with an oscilloscope or digitized and stored on the computer. You are going to measure the time difference between these correlated pulses, as well as the amplitude and width of each pulse. After many such observations, you will obtain a distribution of the number of counts vs. time difference. When these data are plotted, they will form an exponential decay curve, whose decay constant is the lifetime of the muon.

This manual is organized to guide the experimenter through a series of suggested procedures. Read this entire manual first, so you know what you will need. Not all the requirements to complete an excellent report are explicitly noted in this manual, rather it is up to you to fill in the missing blanks. There are suggested questions interspersed that you should think about and answer. Some of the questions (and their answers) are quite important and discussion of them should be worked into the laboratory report.

## 2. Physics of muons

Muons have nearly the exact same properties as electrons except they are heavier. Muons can decay due to the mass difference between muons and electrons. Muons and electrons interact with matter only electromagnetically or by the weak nuclear force. The latter causes the radioactive decay of particles and atoms. Cosmic ray muons (this experiment) arise from the decay of pions ( $\pi \rightarrow \mu + \nu$ ) which are produced by high energy collisions of incoming cosmic rays with nuclei in the atmosphere. See below for some estimates of cosmic ray muon fluxes.

When observing nuclear beta decay, one finds experimentally that the decay

$$n \rightarrow p + e^- \quad (\text{violates conservation of } E)$$

seems to violate the conservation of energy. Pauli was first to propose the existence of a massless particle that is now called the neutrino<sup>1</sup> to explain this discrepancy. Then the decay becomes

$$n \rightarrow p + e^- + \bar{\nu}_e.$$

Fermi (1932) developed a theory of nuclear decay in analogy with the electromagnetic interaction. The lifetime of the neutron would be given by  $\tau = \hbar / \Gamma$  with

$$\Gamma = \frac{G^2 E_0^5}{30\pi^3}$$

where  $G$  is a constant, and  $E_0$  is the nuclear energy difference (1.81 MeV). Using the measured half-life of the neutron, we determine  $G$  to be  $1.136 \cdot 10^{-5} \text{ GeV}^{-2}$ .

The muon lifetime can be determined by direct analogy to this decay. Muons are spin-1/2 particles (just like electrons, protons and neutrons) so the decay is given by:

$$\mu^- \rightarrow e^- + \nu_\mu + \bar{\nu}_e.$$

The mean lifetime of the muon is given by  $\tau = \hbar / \Gamma$  where

$$\Gamma = \frac{G^2 m_\mu^5}{192\pi^3}$$

$m_\mu$  is the mass of the muon and we get a constant of 192 instead of 30 because we cannot neglect the recoil of the final electron as we could for the proton in the proton - neutron system in

---

<sup>1</sup>Today, we know the neutrino has a very small nonzero mass ( $< 0.3 \text{ eV}$ ).

nuclear beta decay. Note that the mass of the muon is much greater than that of the muon neutrino or the mass of the electron so  $m_\mu$  is analogous to  $E_0$  in nuclear beta decay.

A full theory of the weak interaction was developed between the mid 1950s and the late 1960s by a variety of people, most prominent of which are Glashow, Weinberg and Salam. See the references for further information about the theory of the weak interaction [3,4]

The muons are produced by high energy collisions between incoming cosmic ray nuclei and nuclei in the atmosphere:

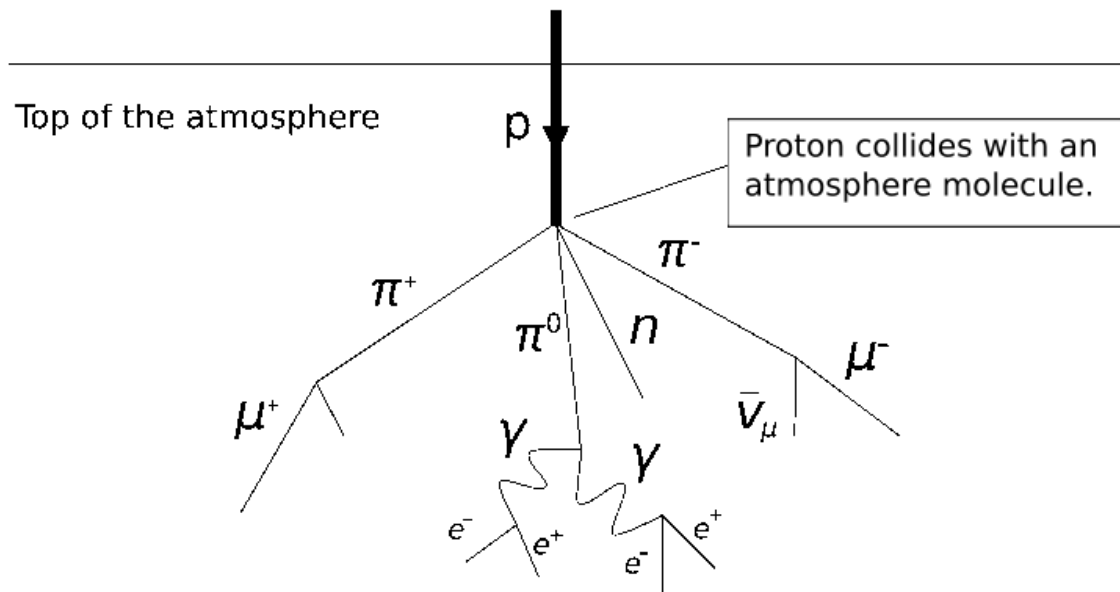

### 3. Muon decay experiment

When a muon is stopped in a material, it is usually captured by an atom of the material. Then, two possible processes contribute to our observed signal. One is that the captured muon decays weakly and gives rise to an energetic electron which can excite the atoms or molecules in the medium. If the medium is a scintillator, light is emitted in the de-excitation of the atoms. The other process is that the muon is eventually captured by the nucleus. It is likely that the product nucleus will give rise to nuclear decay products which will excite the medium and produce light if the medium scintillates. The resulting light will produce a signal in the photomultiplier tube (PMT.) Here we use a big chunk of plastic scintillator as the stopping medium.

- **Question** A singly charged particle traveling in matter nearly at the velocity of light loses energy by Coulomb interactions with the atoms of matter at a rate of about  $2 \text{ MeV}/(\text{gm}/\text{cm}^2)$ . (The denominator is an “area density” and is equal to the volume density

times the thickness.) How much energy is lost by a relativistic particle ( $v \sim c$ ) particle in traversing the entire atmosphere?

- **Question** Compute the muon lifetime given that the mass of the muon is 106 MeV. Compare your answer to the accepted value of  $2.2 \mu \text{ sec}$ .
- **Question** How far will a muon neutrino of 1 GeV travel in the atmosphere if the muon lifetime is  $2.2 \mu \text{ sec}$ ? How far will a 100 MeV muon go? A 10 GeV muon? Neglect energy loss of the muon, which would change its speed.

See below for information on mean range and energy loss. Note that the density of the plastic scintillator (“stopper”) is near  $1 \text{ g/cc}$ . Its composition is close to that of CH. Energy loss or more strictly the rate of energy loss is  $dE/dx$ . Energy deposited  $\Delta E = \langle dE/dx \rangle \Delta x$ .

- **Question** Estimate the number  $R$  of muons passing through the detector each second. (First estimate the size of the detector.)
- **Question** Roughly how much energy will a 100 MeV muon deposit in 1 cm of scintillator?

The scintillator is covered with reflecting foil so that most of the photons multiply reflect and escape through the top. A high gain 14 stage PMT (**max voltage 2500V**) is connected to the plastic scintillator block [see photos below] with an optical grease. About 20% of the photons entering the PMT are converted to electrons in the semi-transparent photocathode. Each one of these electrons is accelerated by a high electric field in the tube, ejecting a few more electrons upon collision with an internal dynode. This tube has 14 dynodes and an overall electron gain of about 100 million ( $3.7^{14}$ ). Each muon traversing the scintillator will produce a pulse of light. Before turning on the high voltage, estimate what muon count rate you expect:

To estimate the arrival rates of single pulses measure the size of the scintillator and estimate the total rate of muon events  $R$ . You can use the following empirical formula that gives a good approximation to the number at sea level as a function of zenith angle:

$$I(\phi) = I_0 \cos^2(\phi)$$

Where  $I_0 = 0.0083 \text{ cm}^{-2} \text{ s}^{-1} \text{ str}^{-1}$  and  $\phi$  is the zenith angle (Rossi 1948, see below.)  $I(\phi)d\Omega dA dt$  is the number of muons incident on differential area  $dA$  during the time  $dt$  within the solid angle  $d\Omega$  from the direction normal to  $dA$ . Integrating this function over the appropriate solid angle you can estimate the total flux from all directions.

Muons lose about 2 MeV of energy per gram per square cm of material that they traverse. Thus muons with less than about 50 MeV will stop in the scintillator (about 0.3%.) These stopped muons will decay within several microseconds, emitting an energetic electron which excites atoms in the scintillator producing another pulse of light. Just as in the radioactive decay experiment, the distribution of these times can be related to the muon lifetime.

Start by doing an initial experiment to find the operating point for the PMT high voltage and for the discriminator. Turn up the high voltage (HV) gradually (about 5 sec per coarse division) and do **not exceed 2500 volts** for the RCA-4522 PMT. You can use the LED pulser for these tests. Look at the analog PMT output pulses (negative, so be sure to use negative scope threshold) as a function of HV. Note that there is a threshold-plateau effect in the response vs. HV (as in the Geiger experiment). You should also look carefully at the noise pulses: PMTs become exponentially noisier at higher voltages (you will have to turn off the pulser for this!) Thus there is an optimum voltage for any PMT which maximizes the signal-to-noise ratio. Look at the changes in pulse shape out of the PMT as the HV is raised. Make sure you avoid operating the PMT over voltages where the pulse becomes ratty. Watch out also for “after pulsing” between 50 ns and 1  $\mu$ sec after the muon stop pulse. This increases at high tube voltage. A superb reference for experimental particle physics techniques is Leo [2.]

**Use the oscilloscope to snoop around your experiment.** Be sure you check and understand the waveforms and pulses at each step. Begin by looking at the background noise level in the electronics with the PMT HV off. While the inputs and outputs of the logic electronics generally are terminated in 50 ohms, the oscilloscope has high impedance inputs, so be sure to terminate the scope inputs with 50 ohms. Un-terminated lines will cause reflections of pulses due to the impedance mismatch with the 50 ohm cable. Be aware of timing effects of cables: A pulse in RG-58 coax travels at  $\sim 2/3$  c, giving a delay of 1.5ns per foot. Read the instruction manuals for the instrumentation, and look over the data sheet for the RCA-4522 PMT. Observe the level of the pulses for the muon decays (smaller than the muon stops) and calculate how much you need to amplify these pulses to overcome noise and drift in the rest of the system (discriminator, etc).

## Setting the discriminators

This is a major part of this experiment. Read and understand this entire section before beginning. You want to set the discriminators such that you count mainly muon stopping and decay events. Consider what processes produce the light signals that are converted into electric signals by the PMT: Cosmic ray muons enter the detector, and some collide and stop. (The higher energy muons pass through). Of those that stop, some decay and some are captured by nuclei. We want to measure the time interval to decay (its distribution).

- **Question** Think about the range of pulse heights produced by stopping muons. Which produces the largest pulse height (largest energy deposited)? Compare this with the pulse height produced when a muon passes through the detector. Sketch expected scope or PHA spectrum of pulse heights (pulse amplitudes). For the stopping case, show the range of amplitudes expected. How much energy will a 2 GeV (the mean at sea level) muon lose if it traverses 12 inches of scintillator? Compare this with the energy lost (signal) of a muon which just stops in 30 cm (12 in). How much energy will the electron from the muon decay deposit in the scintillator if it is stopped? How much scintillator does it take to stop the decay electron? A good estimate is that a relativistic electron loses about 2 MeV per cm (per  $\text{gm/cm}^2$  in CH). Assume that the scintillator is Lucite or CH.

- **Question** Compare range of signals from stopping muons and decay electrons in the scintillator the max electron energy is  $\approx 53$  MeV when electron's momentum is opposite to the two neutrinos. (See Melissinos textbook)

The procedure for setting a threshold for the above detector signals is similar to that used in counting statistics laboratory. Here, one can adjust the PMT voltage and measure the counts above a fixed discriminator threshold; or one can fix the PMT voltage and vary the threshold. In the first case one graphs the count rate over a small (say -30mV) discriminator threshold versus the applied voltage for the photomultiplier tube. Use the Ortec counter. Beware that if your discriminator level is too low, you will count mostly electronic noise, and if it is too high, you will see nothing at all. Investigate this experimentally first with the scope. There is a not a nice plateau as in the Geiger experiment, because one has a wide range of pulse heights. However the operating point is not that critical. Look for a change in the slope of a graph of counts vs. threshold, or  $\log(\text{counts})$  vs. threshold. *You can also use the LED pulser (which injects pulses of light into the scintillator) to get constant amplitude pulses, giving a nice plateau vs PMT voltage.*

This allows you to check that your PMT voltage-discriminator setting is reasonable, so that you are seeing muon decay signals. *Start out by using the oscilloscope to look at signals out of the PMT and determine the signal sizes of the electronic noise, a muon passing through the scintillator and an electron decaying after a muon has been stopped in the detector.* The last will be the hardest to find. The signal of the decay product electron will occur on average about 2  $\mu$  sec after the muon stops. Lower the scope discriminator level until the digital scope triggers all of the time (you will now be triggering on the electronic noise). Increase the scope discriminator level until you no longer see the electronic noise and you see both muons and the occasional electron from muon decay on the scope. Note that stopping muons and stopping electrons will have a higher signal than muons that simply pass through the apparatus. [You may want to capture this in memory for your lab book and report.]

Once you have the basic idea of what the signals look like, and have chosen the best discriminator level as displayed on the scope, set the NIM discriminator level. Note that the Lecroy discriminator has a test point on the front panel (use a volt meter to test) giving 10 times the discriminator level (300mV = 30mV discriminator level); the level adjustment can be made from the front panel using a small screwdriver. After adjusting this discriminator level, please do not adjust the NIM threshold level further so as to extend the life of these potentiometers. As a check, use the output of the NIM discriminator to trigger the oscilloscope. Be sure this NIM discriminator setting gives decay events with the amplitude and rate you expect.

## Logic Electronics

You will be using NIM logic electronics in the fast-negative logic mode. In fast-negative logic, usually referred to as "NIM logic", logic levels are defined by current ranges. Since the standard also requires 50 ohm input/out impedances, these current ranges correspond to voltages of 0 V

and -0.8 V for logic 0 and 1 respectively. Fast-negative logic circuitry can provide NIM signal with rise times of order 1 nsec. Beware of overloading logic outputs by simple tee cable connections to other logic inputs -- use fanout logic instead. We highly recommend you read the relevant section of ref [2].

To measure the muon lifetime you need to collect statistics on the distribution of times between the first pulse (arrival of the muon) and the second pulse (decay.) The first pulse is used to start a timer (actually a time-to-amplitude converter -- TAC) and the second pulse used to stop it. When the START pulse is received, the TAC begins a positive voltage ramp. When a STOP pulse is received, the ramp voltage at that time is output to the analog-to-digital converter (ADC) in the data acquisition system (DAQ) and sampled. If no STOP pulse is received within a preset time (10  $\mu$ sec) the TAC is reset and the process starts over. The distribution of amplitudes of the TAC are then analyzed.

- **Question** You are trying to take the difference in time between a muon stopping and its subsequent decay. You need to have a start and a separate stop pulse to carry this out. What signal will be used for the start? There is only one output signal from the PMT, so how can you set up a stop that is different than the start?

You only have one detector and one output so you have to use the same output to derive both a start and stop signal. To avoid inhibiting the timing sequences by the simultaneous arrival of every pulse at the START and STOP inputs of the TAC, the pulses to the START input must be delayed to insure that their effect at the STOP input is finished before the timing sequence is initiated. Every pulse that triggers the discriminator should start a timing sequence which will be stopped by the next pulse that arrives at the STOP input, provided it occurs before the end of the TAC timing ramp. In the circuit below we use a 100ns delay.

- **Question** What effect does this necessary delay of the start pulse and the consequent loss of short-lived events have on the mean life measurement?

You must calibrate the TAC by correlating different time delays between the START and STOP pulse and the TAC output pulse height measured by the DAQ. Introduce a fixed delay between the START and STOP pulse: use an adjustable gate to delay the STOP pulse. You will need a calibrated oscilloscope, an adjustable gate and a multi-discriminator.

**1.** Select the TAC time scale that was used to collect your data. **2.** Using two of the outputs from discriminator 1, name one A and the other B. Connect A to Ch1 of your oscilloscope and set the trigger to a negative pulse and the threshold to -100mv. (note: a pulser + separate discriminator may also be used) **3.** Select the time scale of the gate to match the time range of the TAC. **4.** Connect B to the input/start of the gate generator and the appropriate output of the gate to Ch2 of the oscilloscope. **5.** Observe and measure the time difference between the negative square pulse from CH1 and CH2. Adjust the delay between the output of A & B with the set screw on the gate generator. **6.** Pick a time delay and connect A to the START and the output of the gate to the STOP input of the TAC. **7.** Start a data acquisition run and record the

time delay used and the maximum pulse height in digital units (DU). **8.** Repeat step 5-7 to collect several data points over the range of the TAC and produce a calibration curve to compute the conversion factor between DU (0-4096) and time.

- **Question** What are the background signals in this measurement? That is, how will we be fooled into believing that we have measured a decaying muon when in fact we have not? If you had other detectors, how might you veto such events?
- **Question** Why the 100 ns delay?

You can use the NIM logic electronics, a fast (>200 MHz dual channel oscilloscope), and the DAQ to make most if not all of the measurements required for this laboratory. The block diagram on page 9 will give you a basic idea of the experiment layout with regard to the pulse train. Each step (box) in the diagram is performed by a different module. You've probably guessed that the discriminator box represents the discriminator module however some of the other modules are not so obvious. In order to successfully perform this experiment you must understand what each module's role is in processing the PMT signal. The manuals are a good place to start but an even better way to learn is to input a known signal or signals into each module and then look at the output(s) on the oscilloscope. Once you understand what each module does to the signal it should be a relatively simple matter of feeding the output of one into the input of the next. Below on page 10 is a suggested electronics layout. It will be useful for you to make a logic timing diagram and include it in your lab book and report.

- **Question** The lifetime of a muon is  $\sim 2 \mu\text{s}$ . What scale should you put the TAC on in order to be able to measure the lifetime effectively?
- **Question** Given the high speed nature of the pulses you're working with, can you simply split a signal using a T connector?
- **Question** How does the coincidence module decide if two signals coincide and what does it output if they do?
- **Question** What kind of noise do these modules add to your signal as it passes through them?

## The run and the analysis

Before you begin your final data run, make sure you understand and document every aspect of the experiment, from the PMT to the DAQ. Information sheets for each of your NIM modules are available on the PHY122 web page for this experiment. You should fully understand each one, first by reading the info sheet and then by observing its response to input signals with a scope.

Undertake mini-experiments: Are you operating the PMT at an optimal voltage? Do you have enough gain after the PMT to overcome system noise and baseline drift? Is the discriminator set optimally for detecting both the stopping muons and the less energetic electrons from the muon



decay? Is this discriminator level too close to the system noise? Are there any systematic errors? [*Measure, attempt to eliminate, and document systematic errors.*] What components of the background counts vary with time? Is there a light leak? Finally, if all the pulses and rates look right, and you have thoroughly checked out the experiment with a test run, begin your main data run. How long should you run the experiment? How many counts do you need to collect in order to achieve a 1% measurement of the muon lifetime? Finally, you should estimate your background counts. You will be fitting a decaying exponential (from the muon decays) plus a small constant (the background). Use a statistically weighted fit. You may have to exclude some data at short times [*why?*]

Obtain a histogram for the decay rate as a function of the time after the muon enters the detector and announces its presence. We expect the distribution (the histogram) to be described by an exponential function. Rather than fitting with an exponential function, some students find it is more convenient to plot the logarithm of the decay rate (minus the background) as a function of time and then fit a straight line to it. Since each data point has a statistical error associated with it, what happens to these errors when the semi-log histogram is plotted? Explain and illustrate.

In your written report, calculate also the errors (random and systematic) in your measurement of the muon mean lifetime. There is a competing reaction happening in parallel: since you are quoting muon *decay* time, you should correct for the effect of negative muon *capture* by a nucleus in the scintillator. Give a brief summary of how a scintillator and PMT work. Explain why, if the START pulse due to the muon arrival were delayed by 1  $\mu\text{s}$ , you do not measure the mean lifetime of the muon as 1.2  $\mu\text{s}$  [since the STOP signal from the muon decay is not delayed.]

Remember, you will have to calibrate the TAC-PHA (Pulse Height Analyzer) combination so that you can accurately convert the PHA channel numbers to microseconds.

## References

1. Melissinos & Napolitano, "Experiments in Modern Physics," Academic Press 2003, Chapters 3.3, 8.4 & 9.4.
2. W. R. Leo, Techniques for Nuclear and Particle Physics Experiments, Springer-Verlag, 2nd edition. (UCD Library call number: QC793.46 L46)
3. David Griffiths, "Introduction to Elementary Particles", John Wiley and Sons, 1987.
4. Francis Halzen and Alan D. Martin, "Quarks and Leptons: An Introductory Course in Modern Particle Physics", John Wiley and Sons, 1984.
5. B. Rossi, "High Energy Particles", Prentice Hall, 1952.
6. R.E. Hall, D.A. Lind and R.A. Ristinen, Am. J. Phys. 38, 1196 (1976).

Tony Tyson,, Matt Klint, Brian Barnett 17 February 2012

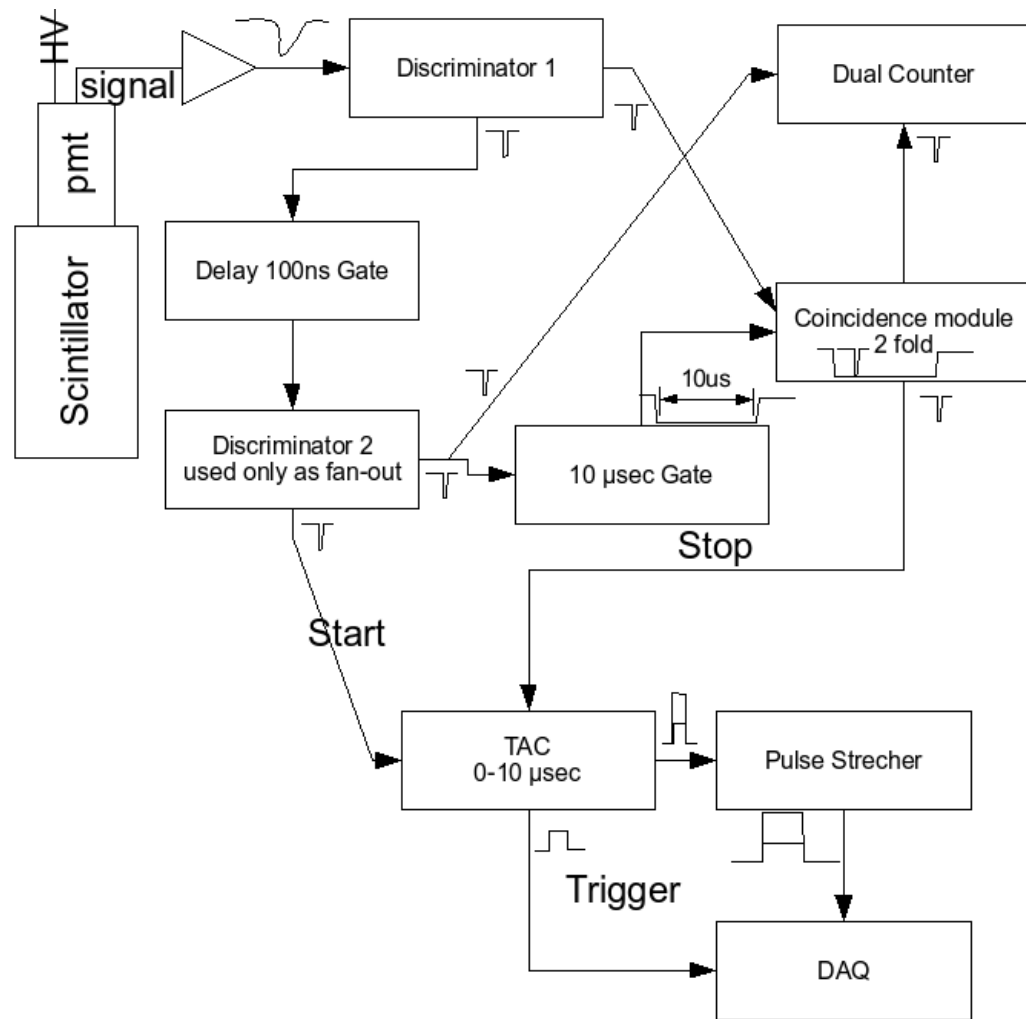

## Data Acquisition system (DAQ) Instructions for the Muon Lifetime experiment

1. Find the Muon lifetime executable
2. Double click on the Muon\_lifetime\_exp.exe
3. Type a valid path and output text filename. (Note that files with the same name will be over written)
4. Select the first channel, channel "a0", in the channel selection box
5. Set the digital trigger selection box to "Rising"
6. Set the sampling rate to 1.25MS and the number of samples to 20
7. Select the upper and lower edge for the histogram. ( Default: 0 and 4096)

8. Select the desired number of bins for the display histogram (Default:256 bins)

9. To start the data acquisition, click on the  icon of the top toolbar

### **Description of the Muon Lifetime exp lab data acquisition Interface**

The muon lifetime experiment consist of 3 displays, a pulse sampling display, a histogram of the events in the buffer and an accumulated event histogram showing all the events collected.

### **Displays**

The TAC output amplitude sampling display is located in the top left window of the application and displays the result of sampling the square output pulses from the TAC. The Max sample box above the sampling display indicates the maximum pulse height that was recorded.

The events in buffer histogram shows the pulse height spectra of event that were collected in the previous buffer before being added to the accumulated events histogram.

The accumulated events histogram shows the pulse height spectra of all events up to date.

### **Other info boxes**

The events in buffer text box is the number of events that occupies the current buffer.  
The events to date indicates the total number of events that was collected in the buffer.  
The stop button closes the data file and terminates the data acquisition.

The TAC output of each event is recorded in the output text file as 2 column of integers. The first is the event number and the second is the TAC output stretched pulse amplitude, which ranges from 0-4096 (12bits).

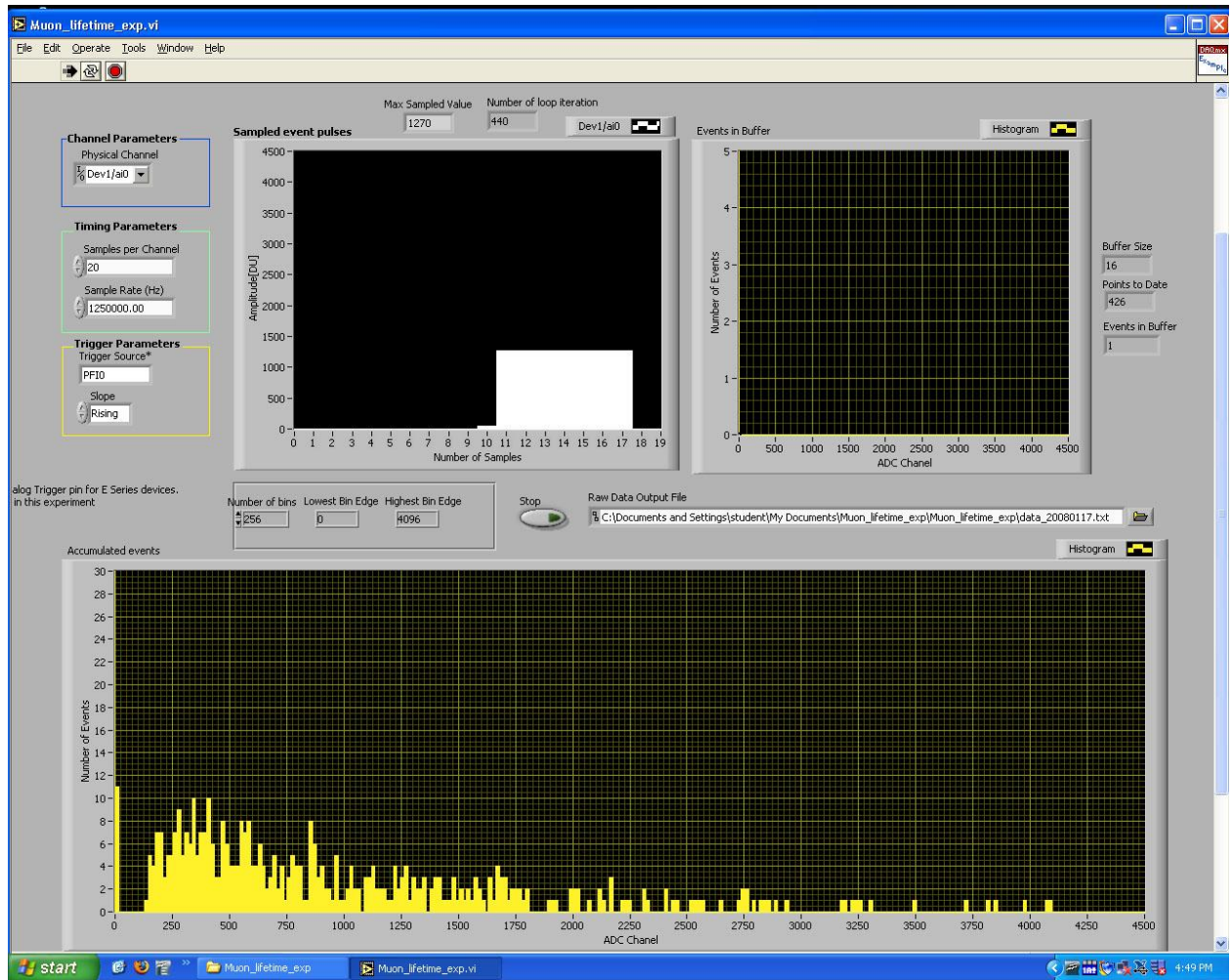

The display for the muon lifetime PHA GUI after only a couple hours of run time. The amplitude of the output of the Time-to-Amplitude-Converter (TAC) for each decay event is sampled (12 bits) by the Data Acquisition (DAQ) card and displayed at the bottom on the x-axis as 0-4096 (0-10  $\mu$ sec.) This screen shot shows the distribution of 530 decay events. Clearly a longer run time is needed for good statistics.



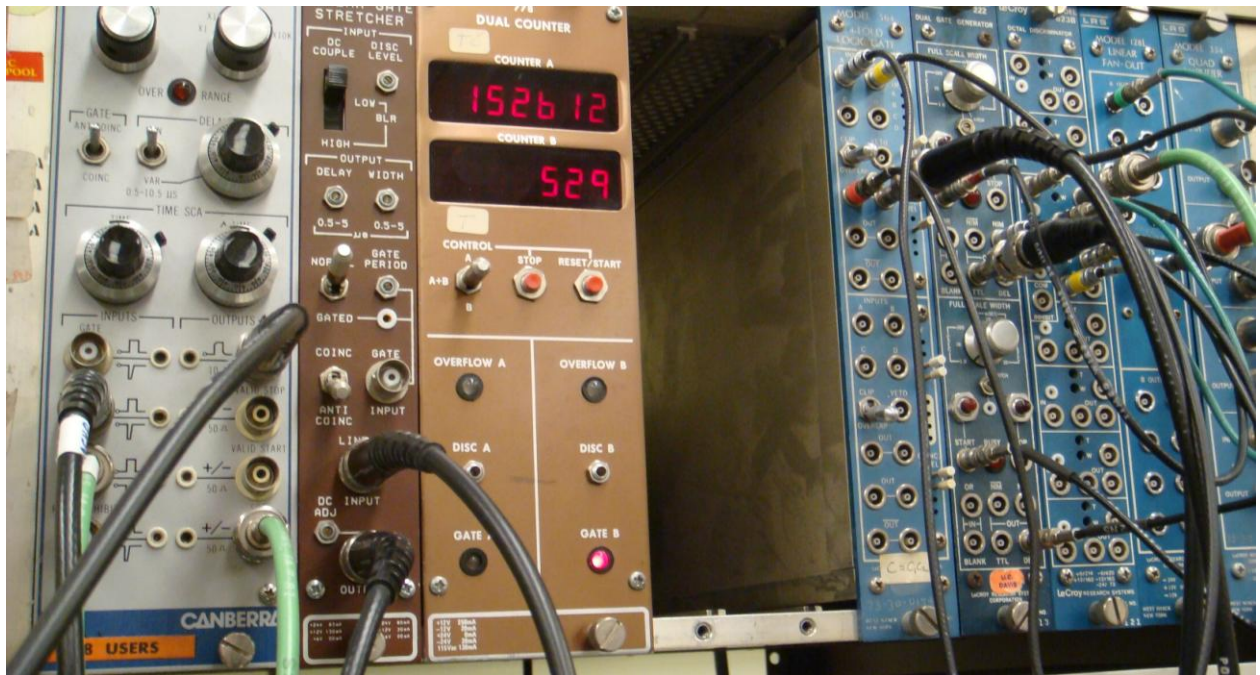
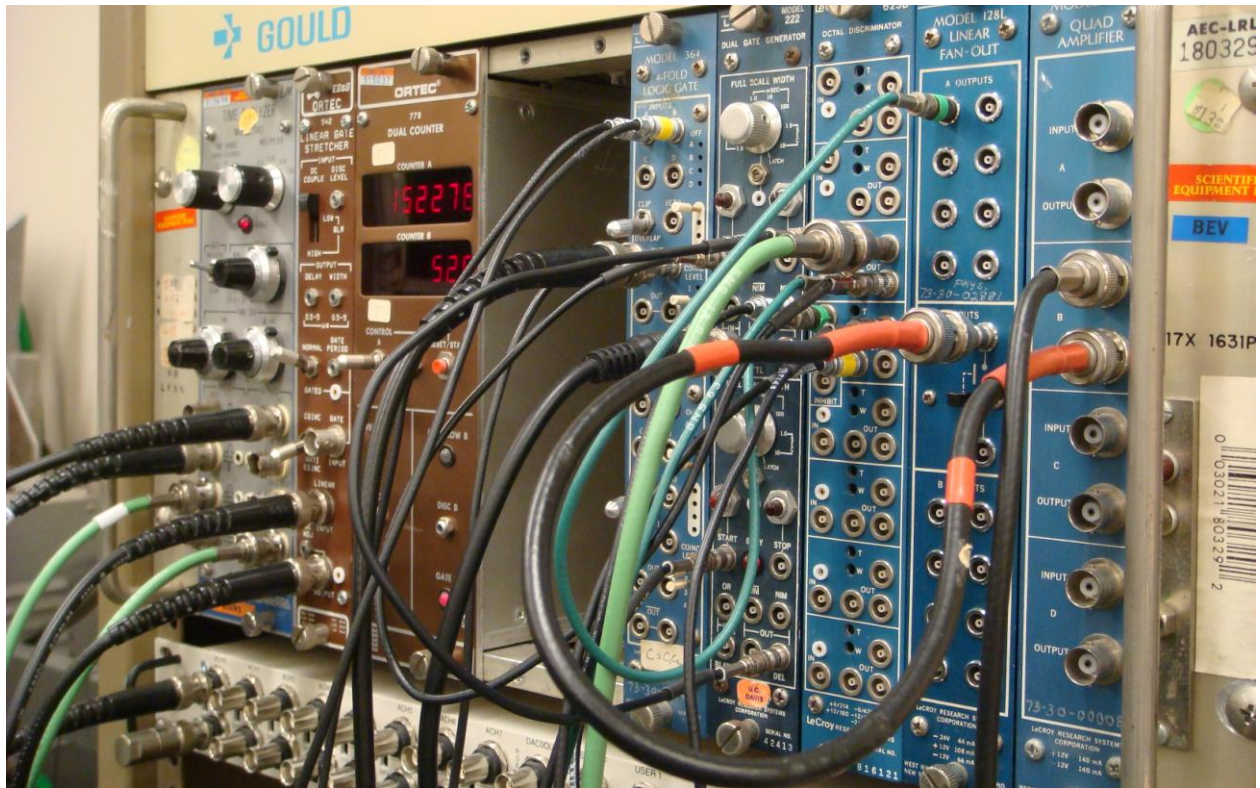



The components of the muon detection experiment before final assembly.

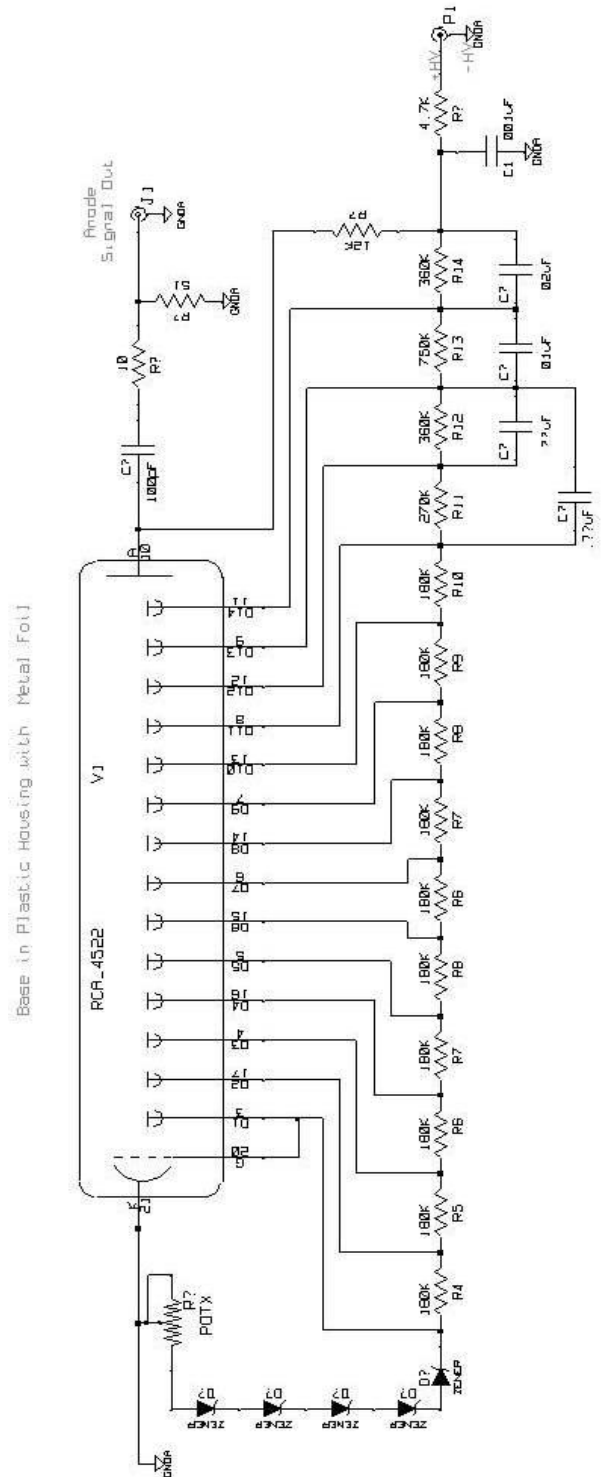





Below is a plot of the vertical intensity  $dN(dA dt d\Omega)$  of the soft, hard, and total cosmic ray flux as a function of the atmospheric depth near the geomagnetic equator [B. Rossi, Rev. Mod. Phys. 20, 537 (1948).] Sea level is  $\sim 900 \text{ g/cm}^2$

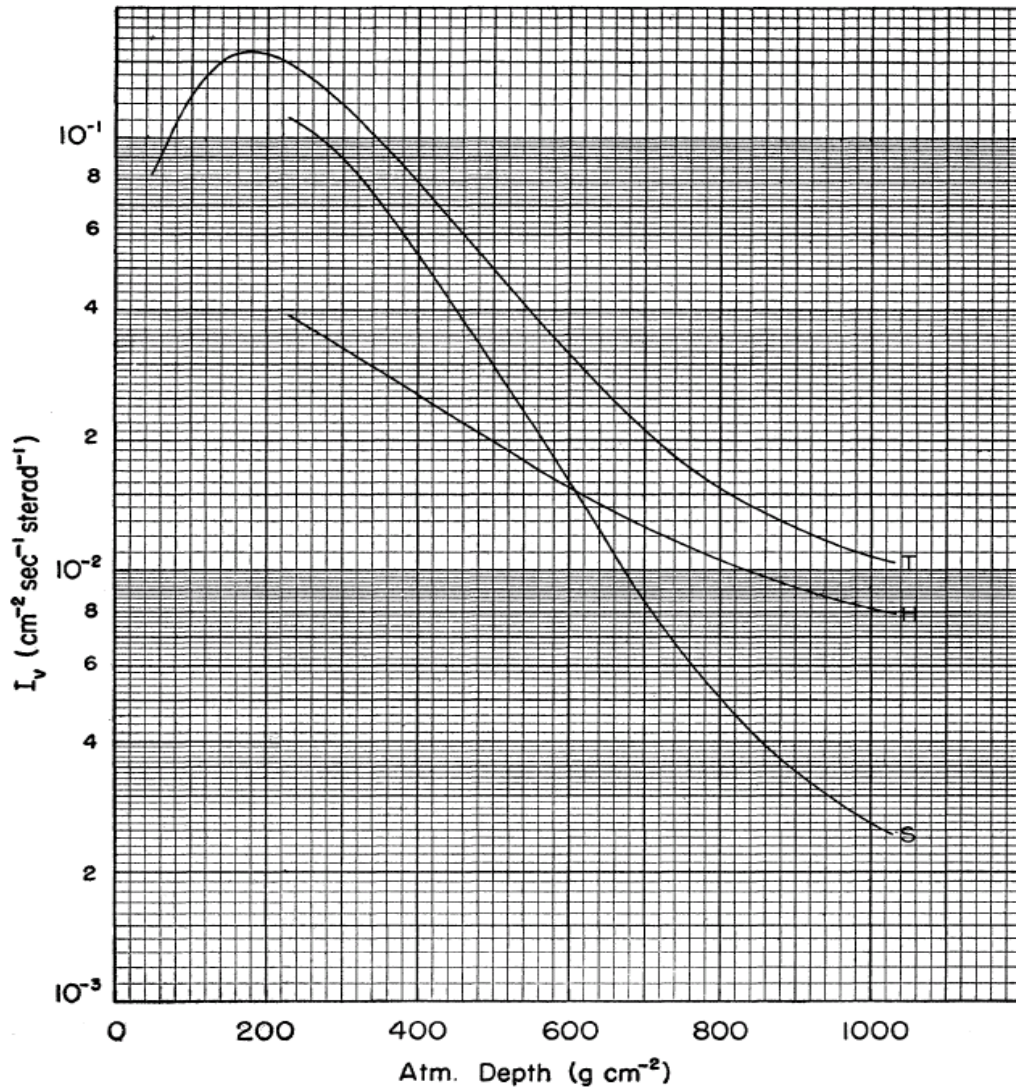



Below is a plot of the differential range spectrum of muons at sea level. The range is measured in  $\text{g/cm}^2$  of air.

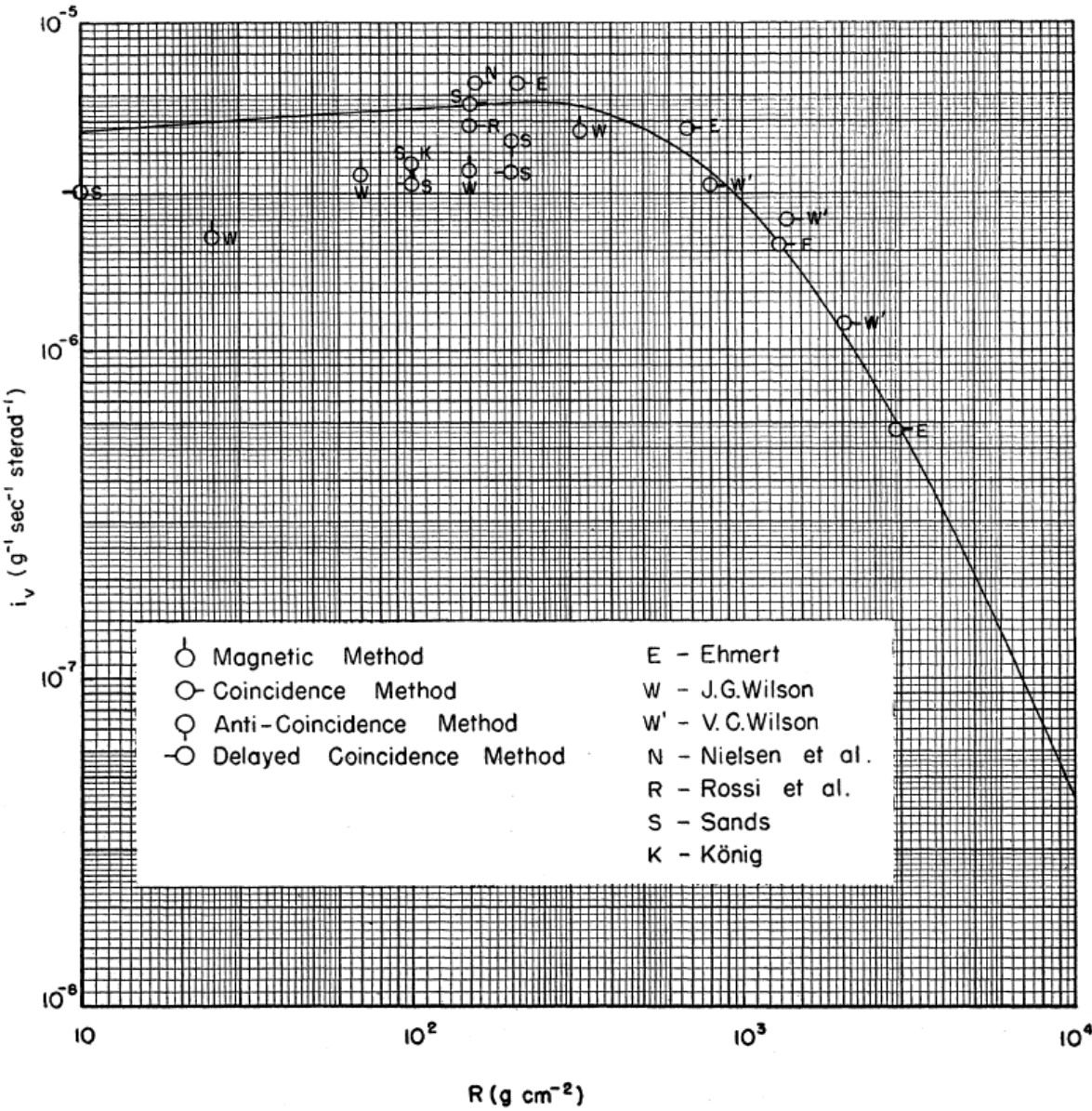

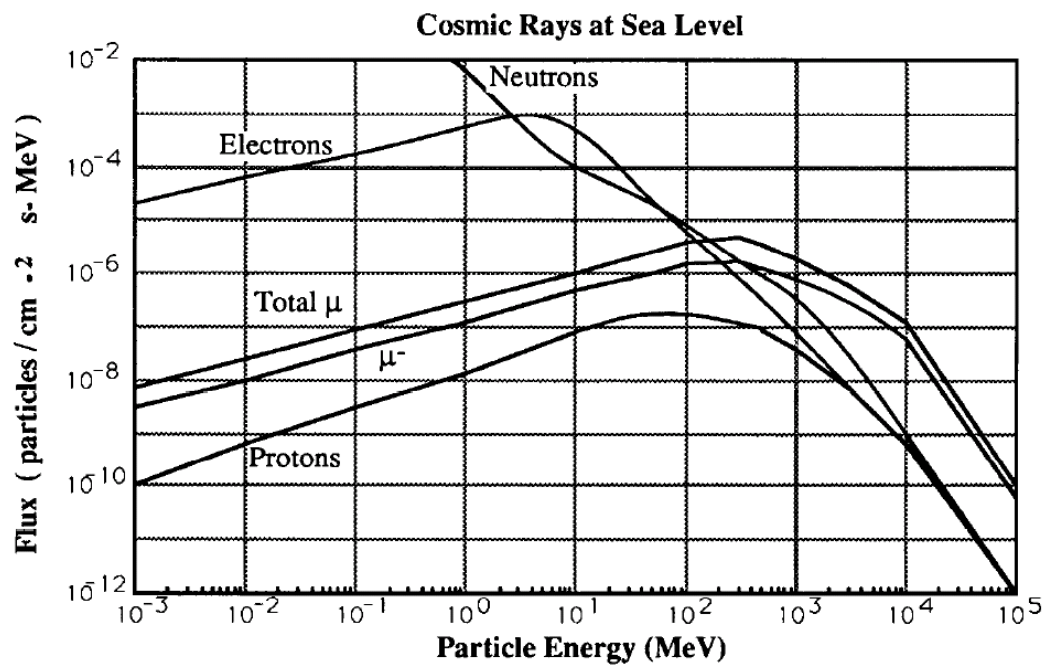

Flux of cosmic ray particles at sea level at 40° N geomagnetic latitude. Data from J. Ziegler, Nucl. Instr. Methods, **191** (1981) 419. Below 3 MeV for electrons and about 10 MeV for protons the fluxes depend on local atmospheric conditions.